

MODELS 331H & 332H EXTERIOR BLOWERS

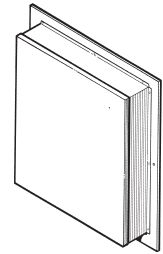

Use this high-powered ventilator to quietly and efficiently exhaust airborne contaminants from cooking and living space.

FEATURES:

- Brushed aluminum construction
- Built-in flashing plate for roof or wall mount
- Built-in backdraft damper and birdscreen
- Easily removable cover provides quick access to blower for cleaning and servicing
- For 10" round duct
- Thermally protected, permanently lubricated motor
- Speed control compatible motor
- Neoprene resilient anti-vibration mounted motor
- Dynamically balanced 10¾" diameter blower wheel
- Low RPM - quiet operation
- For use with Broan-NuTone Hoods and Downdrafts that have exterior blower options

TYPICAL SPECIFICATION

Ventilator shall be a Broan Elite Model 331H (Broan Elite Model 332H).

Ventilator shall be roof (exterior wall) mountable with a 10" round duct connector.

Ventilator shall be of aluminum construction.

Ventilator shall include an automatic backdraft damper.

Air delivery shall be no less than 600 CFM (Model 331H), 900 CFM (Model 332H), as certified by HVI.

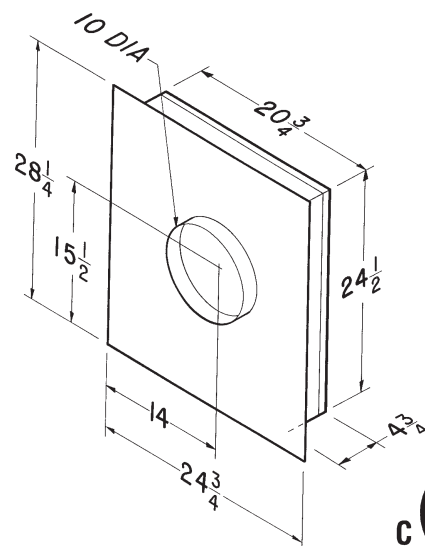

SPECIFICATIONS

MODEL	VOLTS	HZ	AMPS	CFM	DUCT
331H	120	60	2.3	600	10" Round
332H	120	60	5.7	900	10" Round

MODEL 331H

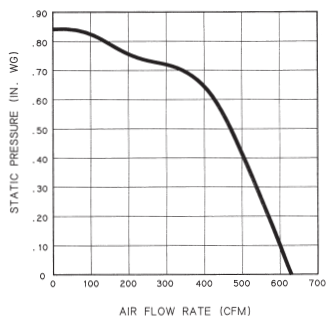

MODEL 332H

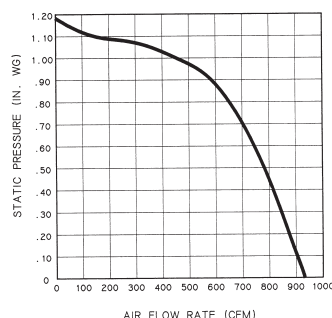

HVI-2100 CERTIFIED RATINGS comply with new testing technologies and procedures prescribed by the Home Ventilating Institute, for off-the-shelf products, as they are available to consumers. Product performance is rated at 0.1 in. static pressure, based on tests conducted in AMCA's state-of-the-art test laboratory. Sones are a measure of humanly-perceived loudness, based on laboratory measurements.

Broan-NuTone LLC, 926 West State Street, Hartford, WI 53027 (1-800-637-1453)

NuTone, Inc., 4820 Red Bank Road, Cincinnati, OH 45227 (1-800-543-8687)

Broan-NuTone Canada, Inc., Mississauga, Ontario L5T 1H9

REFERENCE	QTY.	REMARKS	Project
			Location
			Architect
			Engineer
			Contractor
			Submitted by Date